

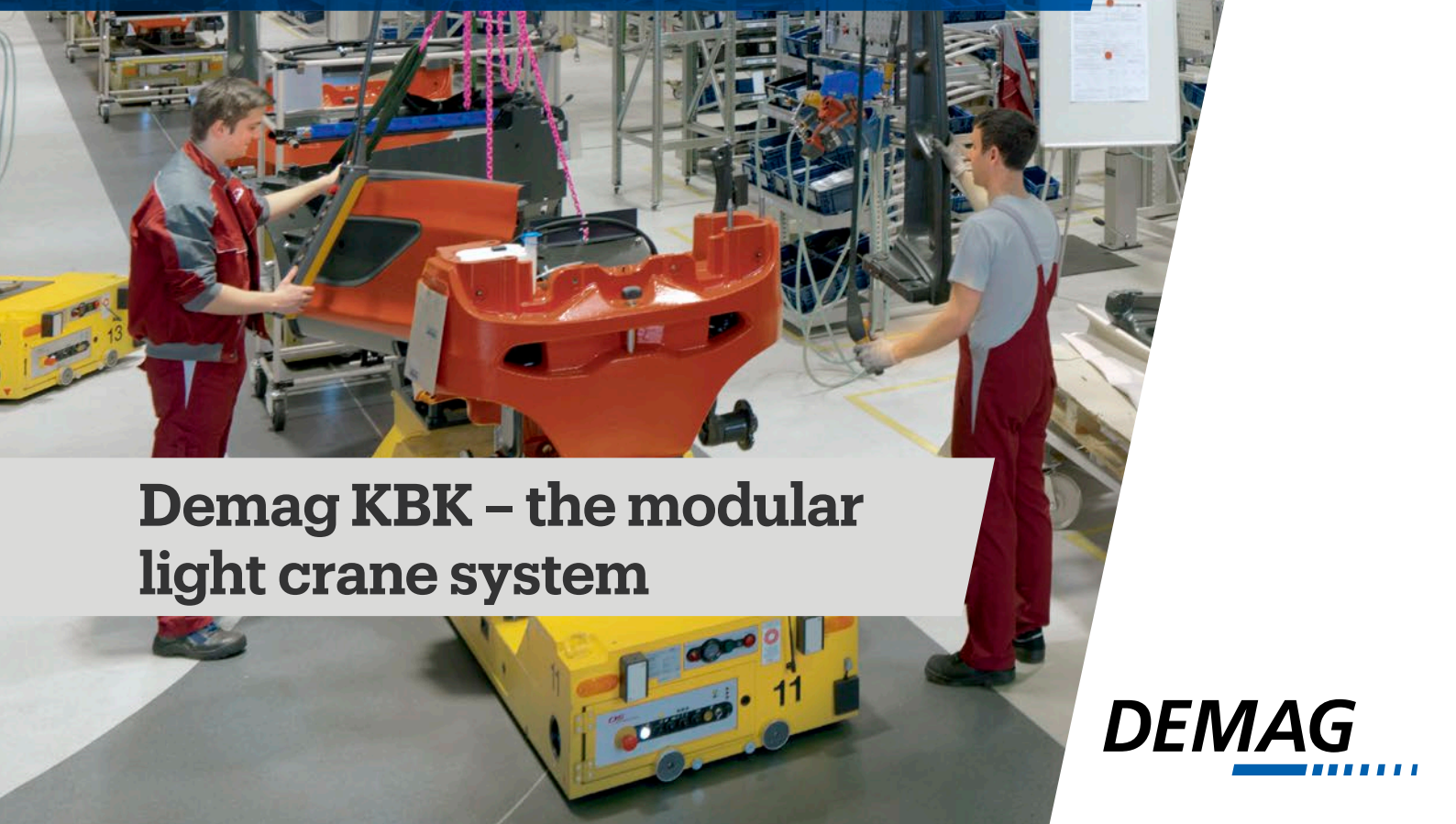

State-of-the-art solutions



Demag KBK – the modular light crane system

DEMAG

One system to meet all your needs

From simple workshop cranes to highly complex material flow systems, with Demag KBK, we can meet all your needs quickly and efficiently. The components of our modular construction kit system can be combined to create individual suspension monorail, suspension crane, pillar and wall-mounted slewing jib crane solutions. KBK installations can also be easily integrated into any production infrastructure – and modified at any time.

VERSATILE AND FOR SPECIFIC NEEDS

The modular construction kit system offers a high level of flexibility. Installations can not only be built with a combination of steel and aluminium profile sections, but existing installations can also be quickly and easily extended and additional components can be integrated. The system includes many matching modular parts for solutions to meet specific requirements.

SAFE, SIMPLE AND RELIABLE HANDLING

Rapid handling and, at the same time, precise and effortless positioning of your loads provide for efficient processes and improve your productivity. The KBK system is ideally suited for complex handling equipment as used in series production lines, such as in the automotive industry.

ERGONOMIC OPERATION

Demag KBK now makes load handling easier than ever before, requiring only little force for simple load handling – both with steel and aluminium profile sections. Reduced loads result in lower absenteeism due to illness and greater employee satisfaction.

RELIABLE

With more than 50 years of experience with light crane systems, our KBK crane construction kit provides for safe and reliable material flow in virtually all industries. Made of standardised products manufactured in large series, our components offer high operating reliability and a long service life.

DEMAG KBK:

- World's largest selection of system components
- Wide range of applications
- Optimum workplace design
- High productivity and efficiency
- Rugged design requires little maintenance
- Broad load capacity range up to 3,200 kg
- Maximum strength for a low deadweight
- Large distances between suspensions and span dimensions
- Can be connected to all building superstructures
- Quality made in Germany



Maximum flexibility

FOR MANY APPLICATIONS

Safe and reliable area-serving material handling



KBK SINGLE AND DOUBLE-GIRDER SUSPENSION CRANES

KBK suspension cranes can be easily moved by hand, which also enables bulky and heavy workpieces to be handled safely and precisely. Since they are suspended from a superstructure, such as roof beams, steel girders or concrete ceilings, they require no additional floor space. Both individual workstations or complete production and storage areas can be fully served with overhead systems. Available in steel or aluminium.

FURTHER DETAILS

- Smooth-running, unhindered operation thanks to flexible suspension of the crane runways in connection with articulated attachment of crane girders
- Customer-specific configuration to meet individual requirements
- Designed for optimum height and can be adapted to building structure or process requirements
- Cranes can also operate on runways that are not parallel
- Very large spans when suspended from more than two crane runways
- Cranes can have overhangs of up to 2.5 m, depending on configuration, load and profile sections
- Electric travel possible for long and cross-travel motions (recommended for large spans or heavy loads)
- Load capacities up to 3,200 kg (steel) or 2,000 kg (aluminium)



- Profile section rail
- End cap with buffer
- Suspension
- ┆ Bolted connection
- Travelling hoist
- Latching device
- ⊖ Travel drive
- ▤ Diagonal stiffener

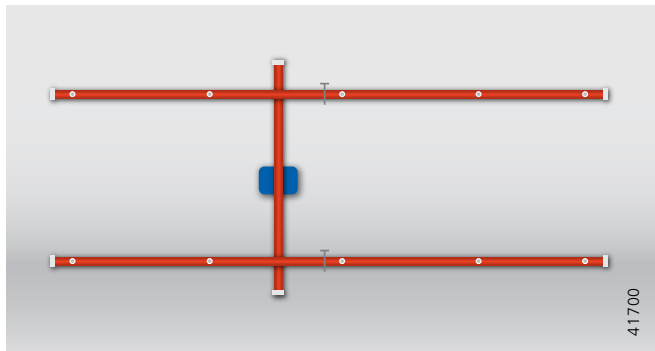

Single-girder suspension crane, parallel track

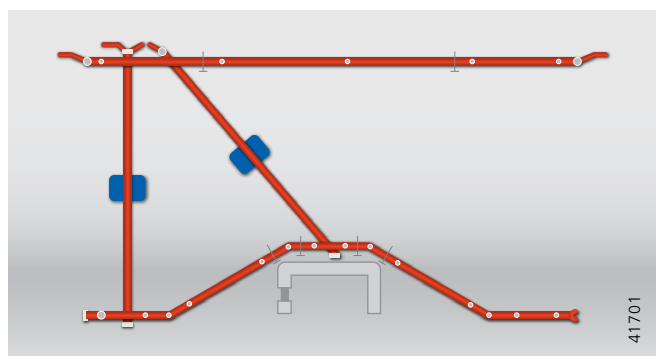

Single-girder suspension crane, angled track

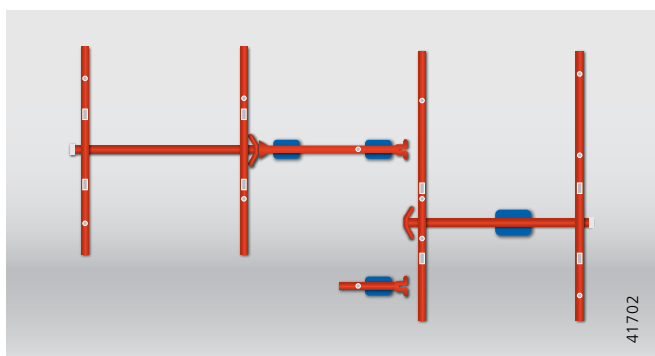

Interlocking single-girder suspension cranes

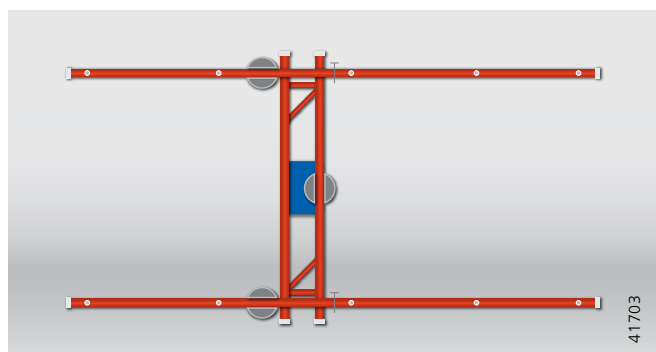

Double-girder suspension crane

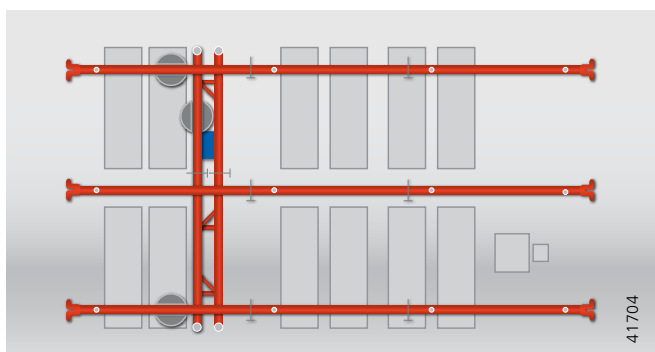

Double-girder suspension crane, on 3 runways

Overview of components: KBK single and double-girder suspension cranes

KBK single and double-girder suspension cranes can be configured to meet individual needs thanks to their modular system design.

1 STEEL SUPPORT SUPERSTRUCTURE

Cantilever supports for universal applications:

- Support system can also be used wherever workshop ceilings and roof structures cannot bear loads
- High flexibility for planning and configuration
- Particularly easy assembly

2 PROFILE SECTIONS

Freedom for planning with a broad range of KBK profile sections to meet differing needs:

- 9 KBK steel profile sections in 6 sizes
- 6 KBK aluminium profile sections in 4 sizes

KBK profile sections are tough and highly resistant to corrosion and impacts. The modular KBK system allows different profile sections to be combined in one installation.

3 TRAILING CABLE

Reliable power supply:

- Highly flexible and cold-resistant flat cables
- Various cable carriers:
 - Narrow cable sliders made of tough plastic
 - Smooth-running cable trolleys

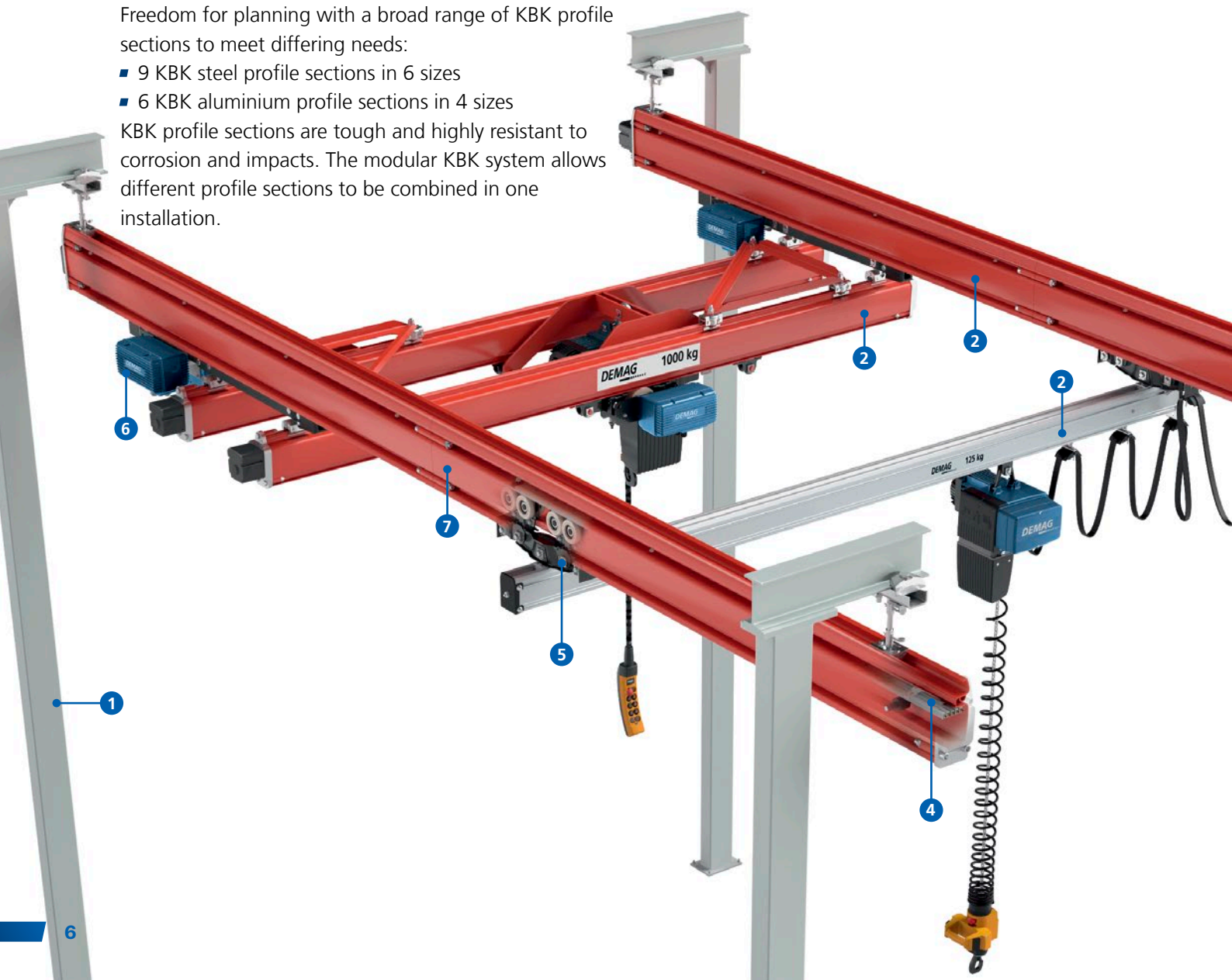

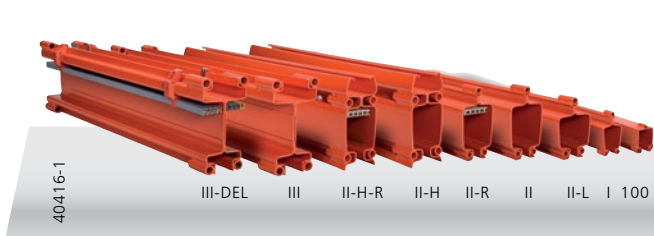

BKK steel profile sections

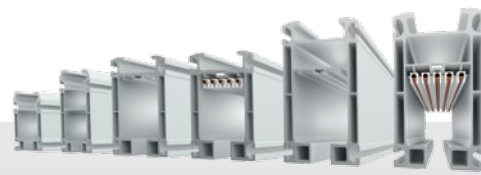

BKK Aluline profile sections

4 INTEGRATED CONDUCTOR LINE

Safe and space-saving power supply via profile sections with integrated conductor line:

- Additional headroom gain
- No risk of collisions (e.g. with forklifts) thanks to lack of cables
- Additional external power supply fittings not required, which minimises assembly times and costs

5 KBK TROLLEYS

Excellent smooth-running performance and minimum rolling resistance over their entire service life:

- Quiet and smooth operation thanks to plastic wheels that are mounted in anti-friction bearings and lubricated for life
- Maintenance-free travel wheels with effective shock absorption
- Compact design with low deadweight

6 TRAVEL DRIVES

Recommended for use with heavy loads and complex installations:

- Electric and pneumatic variants
- Large friction wheels that have a high friction coefficient ensure reliable transmission of drive torque
- High traction: connection between travel drive and track does not depend on position and weight of the load
- Quiet-running drives

7 KBK II-H JOINT CONNECTION

Planning and project engineering can be simplified by the completely rigid rail connections on KBK II-H profile sections:

- The rail joint can be subjected to a full load – regardless of the position of the track suspension
- No additional steelwork required
- Efficient solution with short delivery times since straight sections in special lengths are largely eliminated
- Fast track connection assembly thanks to self-retaining nuts that are secured against turning

8 KBK SUSPENSIONS

Secure attachment with articulated suspensions:

- Significant reduction of horizontal forces in roof and support superstructures
- Impacts and noise minimised by plastic shells in the ball joints
- Exact alignment down to the millimetre thanks to track height adjustment with threaded suspension rods
- Flexible mounting arrangements for connection to various superstructures
- Low maintenance requirement



41600-2

Variable working area, efficient use of space



KBK EXTENDING CRANES

These cranes can also be used for precisely lifting and positioning loads outside the area covered by the crane runway. A valuable benefit: their operating range can be extended to serve almost inaccessible areas, such as between pillars and columns. Available in steel or aluminium.

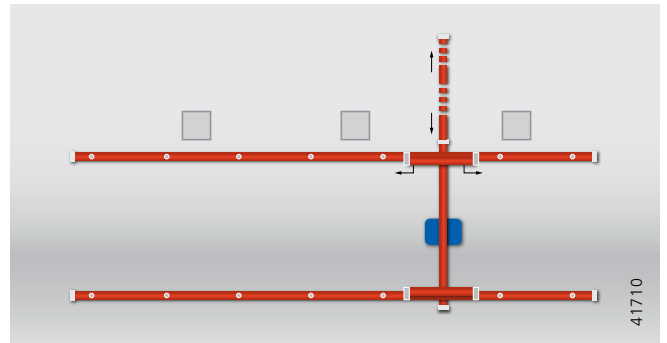

Single-girder extending crane

- Profile section rail
- End cap with buffer
- Suspension
- ┆ Bolted connection
- Travelling hoist

FURTHER DETAILS

- Extending cranes consist of a fixed section and a crane section that can be extended
- High versatility, since the girders can be extended to one or both sides
- Extensions up to 2.5 m in length possible (depending on configuration, load and KBK profile section)
- Particularly ergonomic and efficient operation thanks to lockable travelling hoist, which can save time for the operator
- Push or electric travel (long-travel, extending, cross-travel motions)



Overhead solutions for complex handling tasks

KBK CRANES FOR HANDLING EQUIPMENT

Crane installations or tracks can be used as carrier systems for handling equipment (e.g. manipulators or lifting devices) for rigid load handling and bolting applications. They are optimised to accommodate kick-up forces and torques. Their low deadweight, high positioning accuracy and fast operating speeds form the basis for optimum ergonomics and efficient workplace design. Available in steel or aluminium.

FURTHER DETAILS

- Manual or power-driven travel motions
- Arrangements for electric, pneumatic or mixed power supply

Overview of KBK Ergo components: KBK extending crane and double-girder suspension crane for handling equipment

Ergonomics all along the line:
KBK Ergo can be used to implement
tailored solutions to carry manipula-
tors and lifting devices when kick-up
forces need to be safely
accommodated.

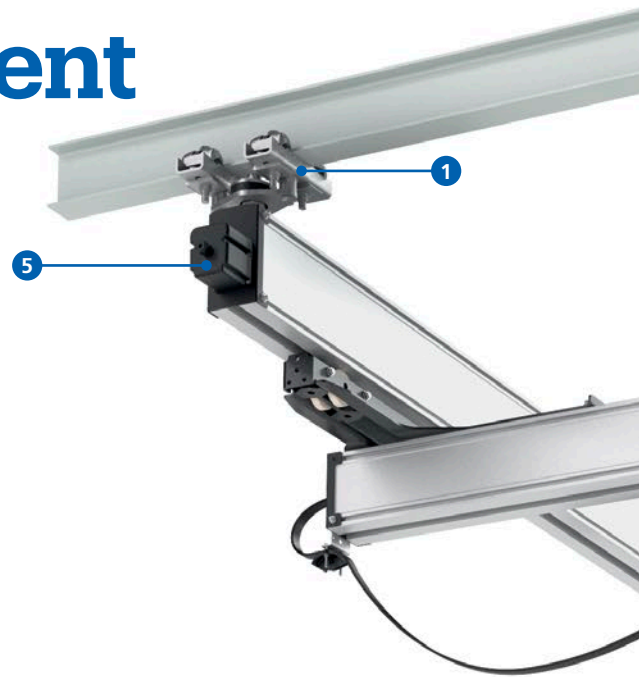

1 KBK ERGO SUSPENSIONS

Safely accommodate kick-up forces:

- Rigid design to transfer forces to the superstructure via rubber damping elements
- Height adjustment with millimetre precision
- Ideally suited for applications with manipulators, lifting devices, extending cranes or offset loads

2 KBK ERGO END CAPS

Easily installed track end cap:

- Precise damping elements for every application: rubber or cellular foam buffers and shock absorbers

3 KBK ERGO TROLLEYS

Optimum travel characteristics and high positioning accuracy also at high operating speeds:

- Smooth travel thanks to lateral guide rollers fitted as standard
- Counter-pressure roller to accommodate kick-up forces, can be adjusted via eccentric fitting
- Universal bolted connection to attach customer-specific handling solutions

4 KBK ERGO CRANE END CARRIAGES

Special end carriage design offering high system rigidity:

- Light-weight design
- Improved positioning accuracy
- Optimum load distribution
- Equipped with Ergo trolleys

5 KBK ALULINE POWERFEED END CAP

- Powerfeed arrangement for KBK Aluline A18-R and A22-R profile sections with internal conductors

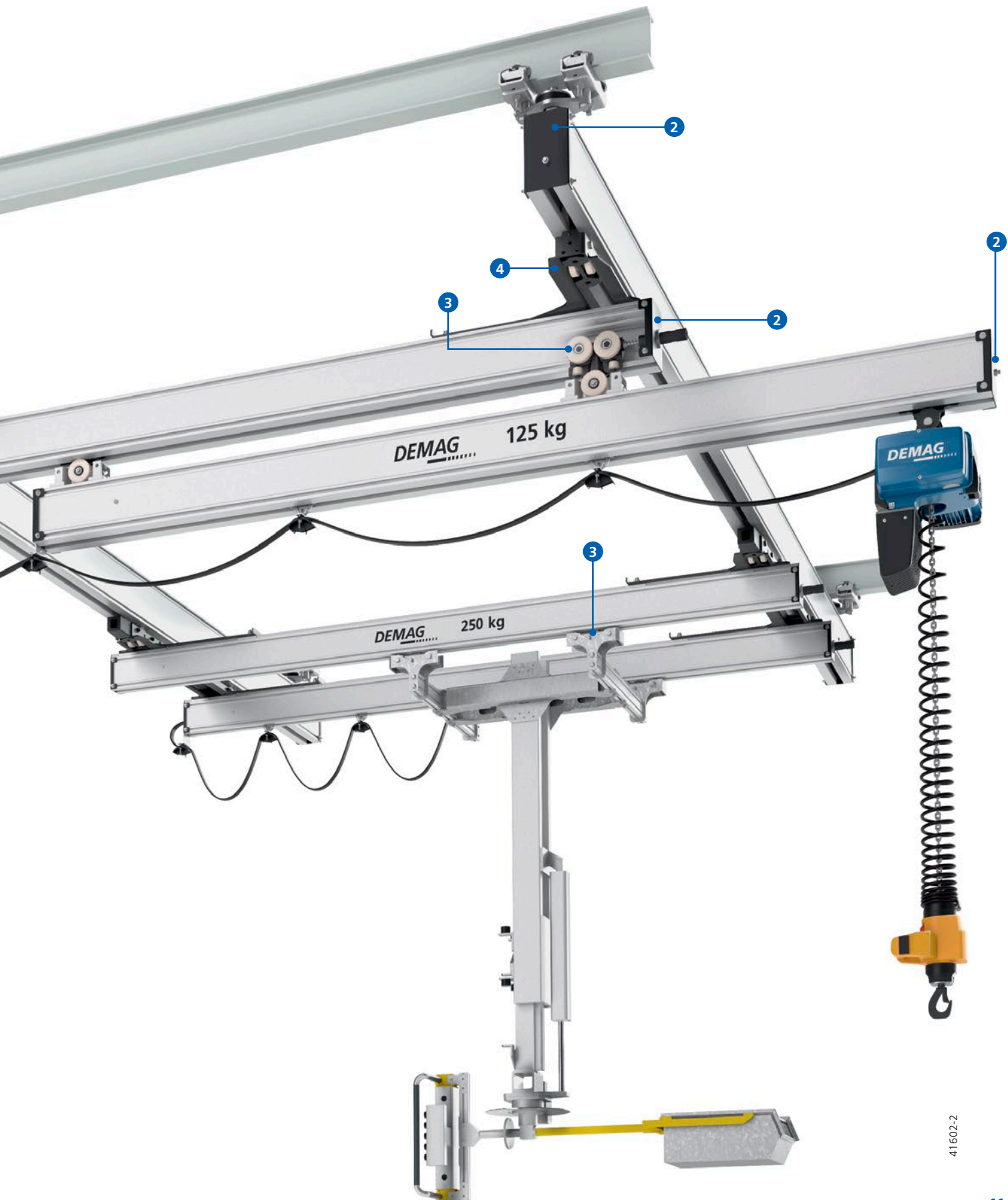

41602-2

Tailored solutions for linear overhead handling



KBK SUSPENSION MONRAILS

Suspension monorails from our KBK light crane system give you the certainty of solutions tailored to meet your specific requirements for linear, overhead handling. Their special strengths are to be found in their many options. Thanks to many system components, such as straight and curved sections, track switches, drop sections or turntables, our proven KBK steel profile sections ensure that your specific requirements are met for handling loads weighing up to 3,200 kg.

FURTHER DETAILS

- Simple straight tracks (also in aluminium up to 2,000 kg)
- Straight double-rail tracks, e.g. as carrier systems for rigid handling equipment, such as manipulators (also in aluminium up to 2,000 kg)
- Semi- or fully automated circuits with many branch tracks – for complex material flow requirements
- Connections between linear and area-serving transport systems: transfer sections to adjacent suspension cranes using latching devices
- Equipment to overcome different height levels
- Push or electric travel trolleys

- Profile section rail
- End cap with buffer
- Suspension
- Bolted connection
- Travelling hoist
- Travel drive
- ⌵ Track switch
- Drop section
- Turntable

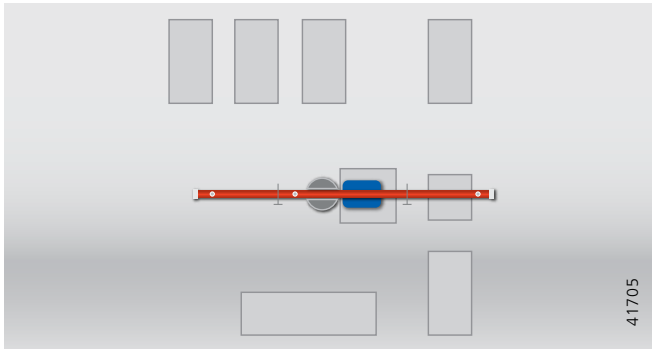

Straight suspension monorail

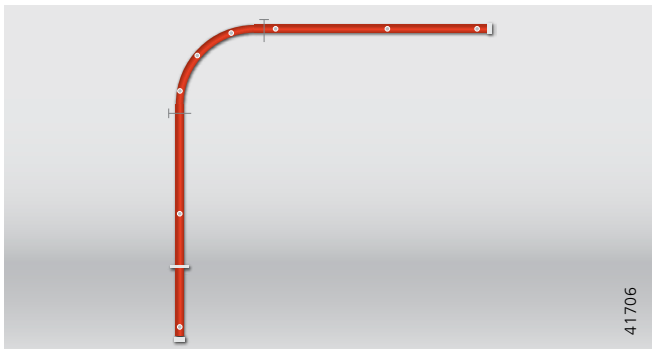

Suspension monorail with 90° curve

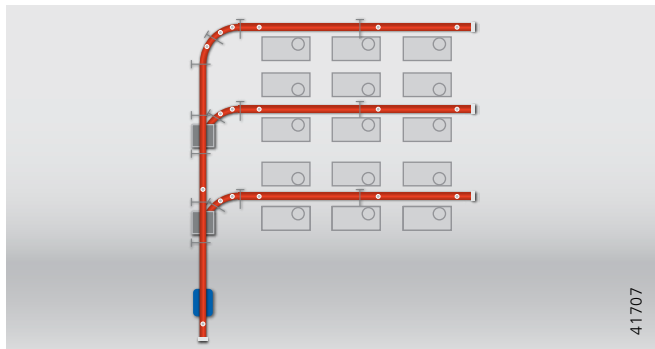

Suspension monorail with track switches

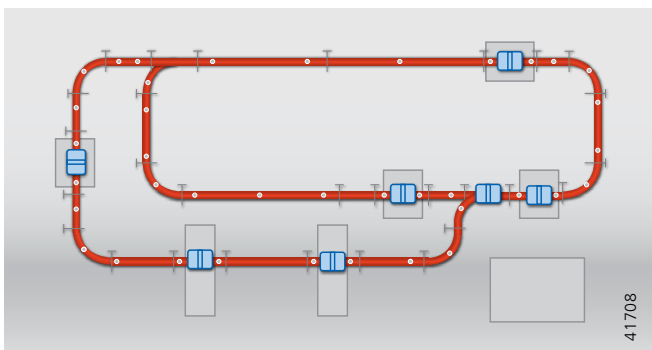

Monorail circuit with drop sections

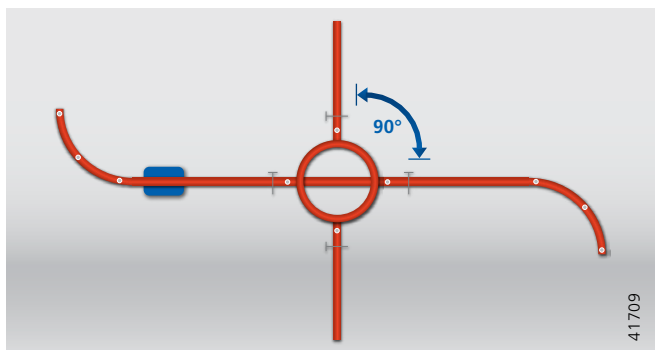

Einschiene-Hängebahn Suspension monorail with turntable

Overview of components: KBK suspension monorail

A wide range of components enables you to adapt the layout precisely to meet the structural requirements of your workshop and gives you maximum flexibility for planning your suspension monorail.

1 STEEL SUPPORT SUPERSTRUCTURE

Portal steel superstructure:

- Support system can also be used wherever workshop ceilings and roof structures cannot bear loads
- High flexibility for planning and configuration

2 CURVED SECTION

Precisely engineered solutions for transporting loads through curves

- Angles between 10° and 90° possible

3 TURNTABLE

Compact design for changing direction through 90°:

- Integrated mechanical locking devices prevent trolleys from entering or leaving the turntable while it is turning
- Manual or electric options to change the direction of travel
- Can be integrated into semi- or fully automatic control systems

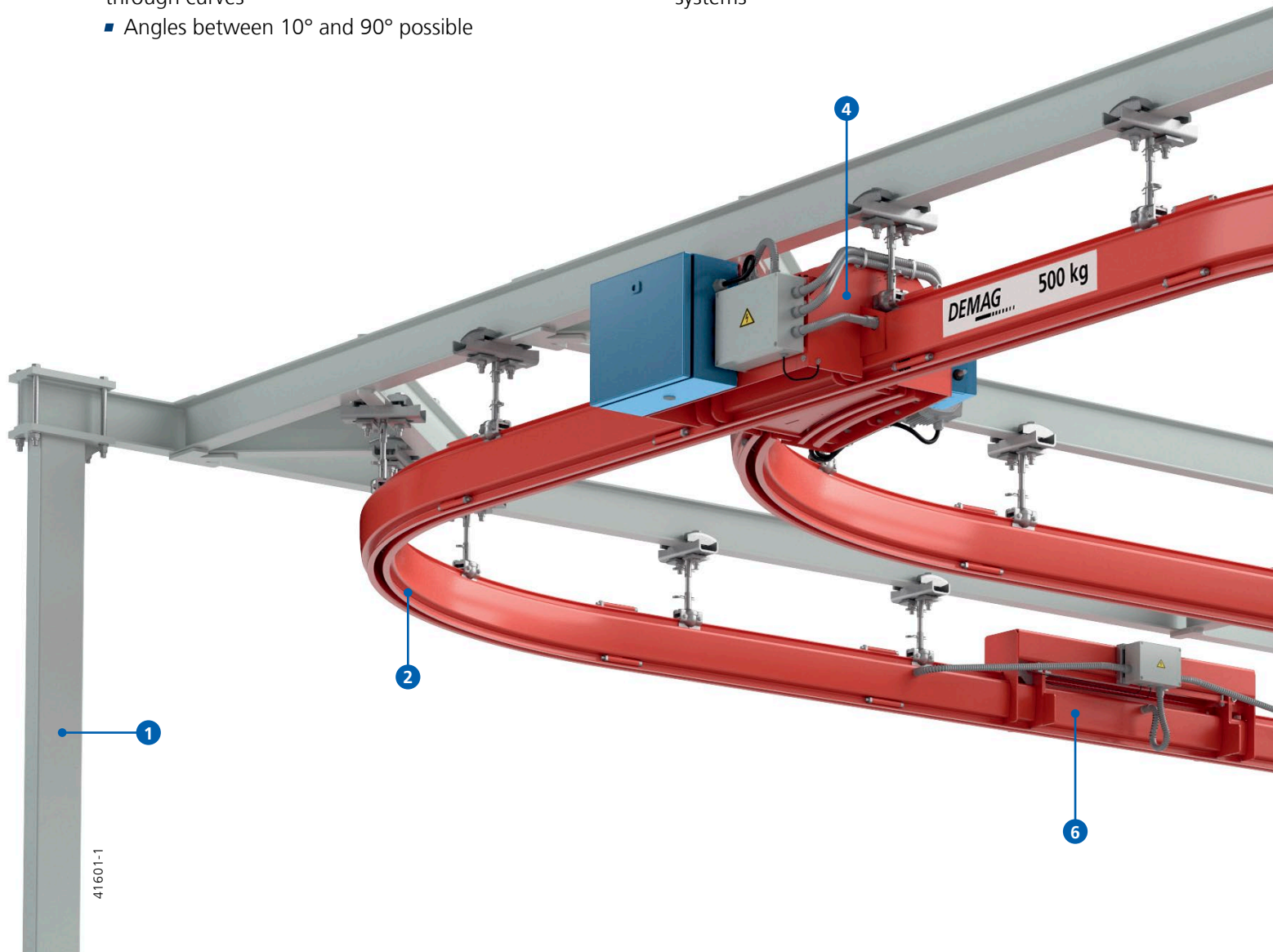

4 TRACK SWITCH

For separating and merging tracks:

- Enclosed, compact design
- Manual, electric or pneumatic options to change the direction of travel
- Can be integrated into semi- or fully automatic control systems

5 TRAVELLING HOIST

Electric travel with friction wheel travel drive:

- Precise positioning and fast handling

6 MAINTENANCE RAIL WITH PULL-OUT SECTION

Saves time and costs for maintenance and repairs:

- Simple installation and removal of travel units
- Pull-out section can be used as an assembly opening
- A fully loaded trolley can travel through it when closed, allowing integration at the optimum position in the track

7 INTEGRATED CONDUCTOR LINE

Power supply arrangement for suspension monorails also with complex layouts:

- Up to eight conductors integrated in the profile section
- Reliable power supply without any external interference contours

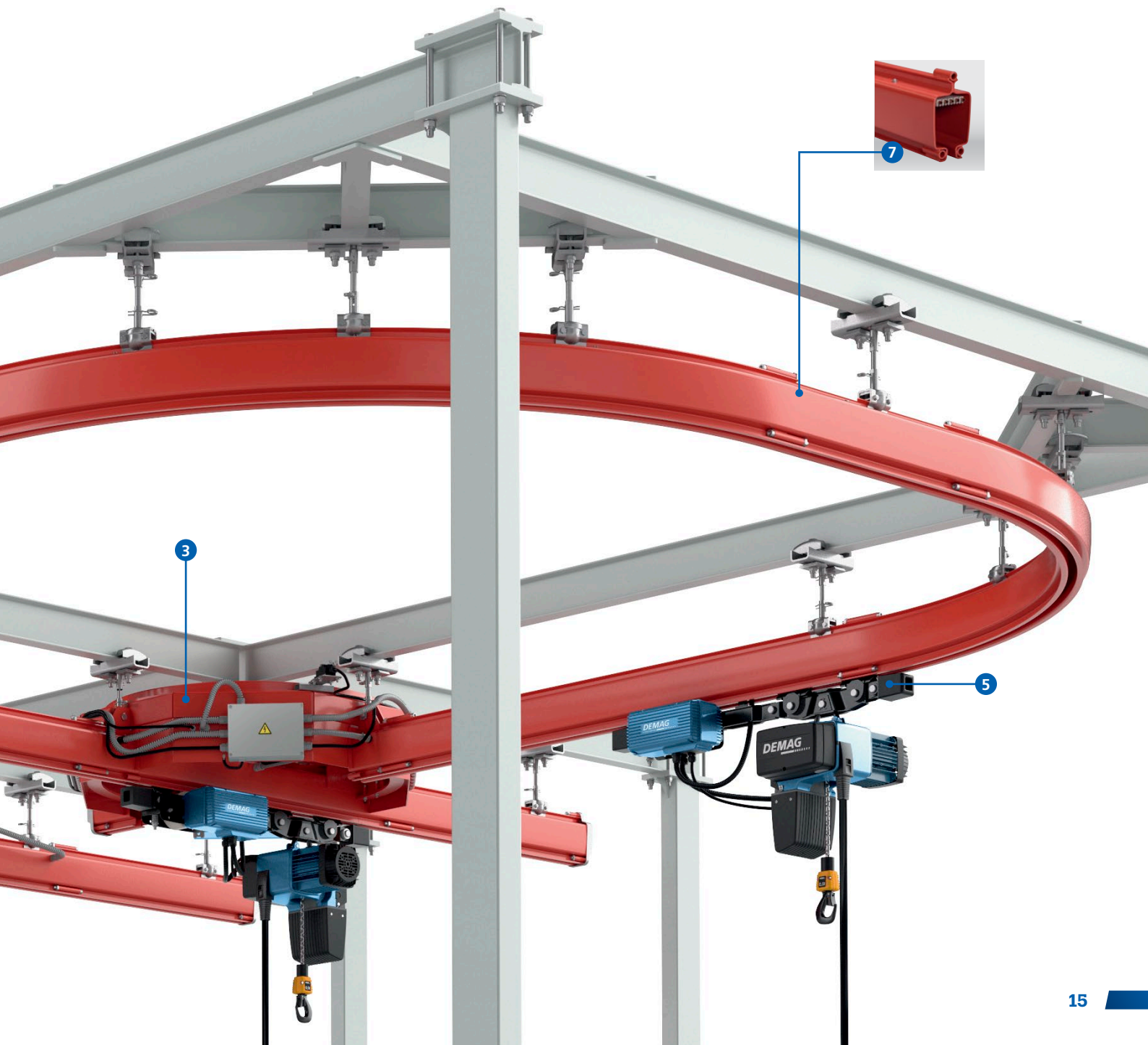

Specialised handling for stores

KBK STACKER CRANES

Unit loads weighing up to 500 kg can be transported and stored with ease – load handling attachments can be simply adapted to the type of load. All tasks can be performed in one operating cycle. Additional equipment such as ladders or order-picking trolleys is not needed.

FURTHER DETAILS

- Combination of KBK double-girder suspension crane and special stacker trolley
- Can be turned through a range of 360°, by hand
- Long and cross travel always by hand, lifting motion via electric chain hoist



39958-2



40562-5-1

Mobile workplace units

KBK PORTAL CRANES

For all applications wherever a permanent crane cannot be installed. Can be easily moved and manoeuvred in any direction – ideal for maintenance and repair work or loading and unloading operations.

FURTHER DETAILS

- Up to 1,000 kg load capacity with KBK hollow profile section
- Up to 3,200 kg load capacity with I-beam girder
- Infinitely adjustable distance between legs

Efficient workplace design



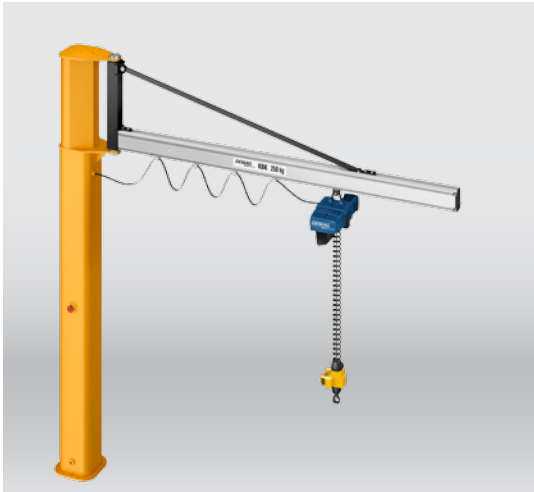

SLEWING JIB CRANES

Effective workplace crane solution to serve a specific working area. Demag slewing jib cranes can be installed virtually anywhere for handling loads weighing between 80 and 10,000 kg. They ensure that all types of workpieces can be lifted quickly and easily, transported gently and deposited precisely, providing handling performance at machine tools and assembly stations, as well as in outdoor storage yards and on loading ramps.

FURTHER DETAILS

- Wall-mounted slewing jib cranes
- Pillar-mounted slewing jib cranes (also available with 2 jibs)
- Pillar-mounted slewing cranes with 360° slewing range
- Manual or electric slewing motion

See brochure 208 755 44 for detailed information.

Demag hoist units, control and load attachment

Demag hoist units are available with a wide range of load capacities, lifting speeds and features. They can also be used with a broad selection of controls and load handling attachments.

Together, these components can provide valuable ergonomic relief for your employees and, at the same time, maximum safety and reliability wherever they are used.

COMPREHENSIVE STANDARD FEATURES FOR DEMAG CHAIN HOISTS:

- High level of safety thanks to 24 V contactor control and operating limit switches
- Flexibility thanks to two sizes of suspension bracket
- Simple commissioning thanks to plug connections
- Gearbox, brake and slipping clutch maintenance-free for up to 10 years
- Smooth and fast load handling with two lifting speeds
- Infinitely variable speed control option for even more precise handling
- Elapsed operating time counter and diagnostics interface provide information on the operating status



DEMAG DC CHAIN HOIST WITH CONTROL PENDANT

- Fatigue-free operation
- Convenient handling thanks to ergonomic housing design
- Comfortable working posture thanks to rapid height adjustability without any need for wiring
- Highly rugged design

DEMAG DCM-PRO MANULIFT AND CHAIN HOIST WITH ROCKER SWITCH

- Ergonomic single-handed load handling
- The chain hoist can be operated while the operator guides the load
- For right-hand and left-hand operation
- Quick-change coupling enables a wide variety of load handling attachments to be connected

DEMAG DC-PRO CHAIN HOIST WITH WIRELESS CONTROL

- The operator can vary his distance to the load for even more safety
- High versatility and availability
- Interference-free radio transmission
- Simple, wireless log-on of the hand-held transmitter
- Stop function according to safety category 3
- Optional pushbutton or joystick transmitter units
- Wireless control also available via infrared



Perfect combination

DEMAG KBK AND HOIST UNITS

BROAD CHOICE OF ATTACHMENTS TO HANDLE SPECIFIC LOADS

The right combination of crane and hoist unit is decisive for the safety and effectiveness of any lifting operation. Besides their weight, shape and material, individual requirements need to be considered in order to pick up, transport and position loads safely and reliably.

A wide range of series load handling attachments are available for standardised loads. Together with Demag KBK and a hoist unit that is optimised for your application, they offer a safe and reliable solution for both workers and materials.

HANDLING SOLUTIONS TO SAFELY PICK UP:

- sheet and plate metal
- pallets
- round and square materials
- barrels
- pipes and tubes
- packages
- boxes
- and much more

Unique workpieces and processes require specific solutions. We can design and manufacture special clamps and grippers that are tailored to meet your individual needs and support your production processes.



Box clamps for handling standard boxes

90° (left) and 360° (right) rotating clamps with spindle adjustment and self-locking drive

Demag KBK product configurator

You can configure a KBK system to meet your specific needs quickly and easily in just a few steps with our online planning tool. You always receive the best possible solution for your requirements with reliable and plausible results.

Your direct access to our product configuration tools:

www.demag-designer.com

YOUR BENEFITS:

- Easy to use
- Specify products to meet your needs
- Save your configuration
- Immediate results:
 - Product description
 - Technical data
 - CAD geometry data
 - Circuit diagrams
 - Documentation
- Online ordering via Demag Shop



Simple planning
WWW.DEMAG-DESIGNER.COM

Service

We offer you a wide range of innovative services to cover the entire life cycle of your installations. From a single source. The same applies to cranes, hoists, load handling attachments and related components of our Demag brand and to products supplied by other manufacturers.

Our goal is to enable you to concentrate fully on your core business by giving you the certainty that your installations operate reliably, efficiently and without any faults or malfunctions.

Our service specialists are always ready to help you with support and advice: from planning the assembly of your KBK system to installation and acceptance approval as well as regular statutory inspections. Demag service engineers are extensively trained and receive continuous further training to maintain their qualifications. The result is extremely high-quality service from a single source.





There is a solution for everything ...

... but the best one can only be found with experience

40976-11

The best solution for all your needs

From simple workshop cranes to highly complex material flow systems, KBK is a tried and tested solution that offers smooth operating characteristics for virtually any requirement.

Benefit from our many years of experience. Our expertise in complex production and operating processes is unmatched in the industry.

Combined with the largest range of standardised light crane system products on the market, the best material transport systems can be created to meet all your needs. These systems help our customers all over the world to succeed and grow their business in future.

We call that: **50 years of experience for state-of-the-art solutions.**

Find out more about KBK expertise on the following pages.

KTR Kupplungstechnik

Rheine, Germany

CUSTOMER REQUIREMENTS

- Versatile handling concept with modular material flow system
- Overhead area-serving crane solution without using any floor space
- Horizontal transport of loads to the assembly and test stations with smooth-running crane systems

DEMAG SOLUTION

- Installation of the crane runways on cantilever profile structure with 6 m outreach
- Use of KBK II-H profile sections with large distances between suspension fittings and rail connections able to bear full load
- Minimum cabling and wiring requirement thanks to conductor lines integrated in the crane runways.
Additional benefit: no interfering contours

RESULT

- Maximum flexibility thanks to multi-functional and modular crane system
- Optimum use of the available space thanks to custom-made support structure for overhead crane system
- Maximum efficiency thanks to high-capacity crane and track profile section
- Solution ready to meet future needs thanks to adaptable system architecture



**Maximum utilisation
of production areas**

41500-17



More efficient welding stations

Knoll Maschinenbau Bad Saulgau, Germany

CUSTOMER REQUIREMENTS

- Simplified positioning of welded sub-assemblies
- Optimised deployment of employees for welding stations
- Overhead solution
- Reduced forklift traffic

DEMAG SOLUTION

- 27 KBK single-girder suspension cranes to serve 45 individual workplaces
- Crane runways made up of KBK III outside-running profile sections for safe and reliable handling of heavy loads
- KBK II crane bridges with spans of more than 5 m

RESULT

- Improved safety – since there is no risk of collisions between workers and forklifts
- Cost savings, since there is no need for additional steel superstructures
- Greater efficiency – since workers are able to move the large welded sub-assemblies into the most ergonomic position without the need for any assistance
- Optimum utilisation of the available floor space thanks to overhead materials handling equipment that requires no additional supports

Hawe Hydraulik

Munich, Germany

CUSTOMER REQUIREMENTS

- Ergonomic workplace design to improve working environment and productivity
- Smooth-running, manually controlled crane installations for assembly processes
- Use of a modular crane system that can also be adapted for future production layouts

DEMAG SOLUTION

- Configuration of light, ergonomic suspension cranes with KBK Aluline profile sections
- Cranes suspended from the workshop roofs

RESULT

- User-friendly, ergonomic solutions for the assembly stations: cranes can be moved with very little force
- Visually pleasing integration into a bright production environment
- Simple integration of new components and replacement of existing units with ease at any time



Drehmo

Wenden, Germany

CUSTOMER REQUIREMENTS

- Ergonomic support for workers for all assembly and test work
- Overhead solution for best possible utilisation of the production area

DEMAG SOLUTION

- 12 KBK suspension cranes for area-serving coverage of all workplaces in pre- and final assembly
- Crane runways suspended direct from the building superstructure
- Use of KBK II-H profile sections for crane runways eliminates the need for additional steelwork

RESULT

- Improved precision in all assembly operations thanks to the use of KBK single-girder cranes with Demag Manulift
- Modifications at a later date possible at any time thanks to modular system design
- High flexibility by relocating the cranes thanks to standard girder lengths of 5.5 m



**No additional
steelwork**



Efficient and versatile indexed production

Linde Material Handling

Aschaffenburg, Germany

CUSTOMER REQUIREMENTS

- Assembly in specified cycles along a circuit with several workstations
- Creation of flexible manufacturing structures
- Conversion of the production line to continuous production at a later date without any additional costs

DEMAG SOLUTION

- Crane systems linked to the process control system by signal encoders
- Traffic light system to indicate completed cycles
- Combination of aluminium cranes and crane runways made of steel profile sections
- Travel drives equipped with disengaging devices to enable use of the cranes in the planned continuous production operation

RESULT

- Reliable and space-saving power supply via integrated conductor lines in the crane runway profile sections
- Ergonomic operation thanks to light-weight crane bridges made of aluminium
- Cost benefit thanks to combination of aluminium cranes and crane runway sections made of steel
- Optimum utilisation of space by employing crane installations without the need for additional runway supports
- Simple adaptation to new production processes thanks to modular design using standard components
- Integrated monitoring of the assembly cycles by smart connection of the crane installations to the control system
- Additional flexibility by employing slewing jib cranes with standardised wall brackets



The technology leader working for you.

We are a world leader for light crane systems. Our engineering and service teams are recognised as the most experienced in the industry. The KBK system is considered to be the one of best modular crane systems in the world.



41594

SUCCESS FOR GOOD REASON

No other system has been on the market as long, no other system can combine so much experience with constant improvement based on continuous research and development. The KBK system production process is always state-of-the-art. And we test our crane systems under the most punishing conditions before they leave the factory. The same also applies to KBK Aluline – the trolleys have run tests of 2,500 kilometers, alone.

MAXIMUM SAFETY, QUALITY AND RELIABILITY

The Demag crane experts are the right partner to ensure the long-term safety, reliability and availability of your KBK installation. We offer you a wide range of valuable services to cover the entire life cycle of your installations. From a single source. And the same applies to cranes, hoists, load handling attachments and related components of our Demag brand and to products supplied by other manufacturers.

50 YEARS OF EXPERIENCE FOR STATE-OF-THE-ART SOLUTIONS

In 1963, we created a new crane segment with our KBK crane construction kit which revolutionised the market for cranes. The modular light crane system changed production processes in virtually all sectors of industry. It made them safer, more profitable and, for the first time, offered our customers maximum modularity, flexibility and operator ergonomics, marking the beginning of a unique success story. Our experience gained over 50 years of the KBK system ensures that you are provided with unmatched expertise for safe, reliable, efficient and state-of-the-art material transport solutions.

OUR GOAL

You can concentrate fully on your core business – since you have the certainty that your installations operate reliably, efficiently and without any faults or malfunctions.

We give you everything you need: a large global service network, highly trained service engineers and a highly efficient spare parts logistics system.



39750-3

0617 EN/DE 208 384 44 701 IS 152
Subject to change. No liability for errors or omissions.
Printed in Germany D/300617/1T

DEMAG CRANES & COMPONENTS GMBH

Wetter Site

Ruhrstrasse 28

58300 Wetter, Germany

E info@demagcranes.com

T +49 2335 92-0

F +49 2335 92-7676

www.demagcranes.com

DEMAG